

MC1458, MC1558 DUAL GENERAL-PURPOSE OPERATIONAL AMPLIFIERS

SLOS069C – FEBRUARY 1971 – REVISED AUGUST 2010

- Short-Circuit Protection
- Wide Common-Mode and Differential Voltage Ranges
- No Frequency Compensation Required
- Low Power Consumption
- No Latch-Up
- Designed to Be Interchangeable With Motorola MC1558/MC1458 and Signetics S5558/N5558

description/ordering information

The MC1458 and MC1558 are dual general-purpose operational amplifiers, with each half electrically similar to the μ A741, except that offset null capability is not provided.

The high-common-mode input voltage range and the absence of latch-up make these amplifiers ideal for voltage-follower applications. The devices are short-circuit protected and the internal frequency compensation ensures stability without external components.

MC1458 . . . D, P, OR PS PACKAGE
MC1558 . . . JG PACKAGE
(TOP VIEW)

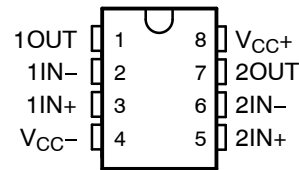

MC1558 . . . FK PACKAGE
(TOP VIEW)

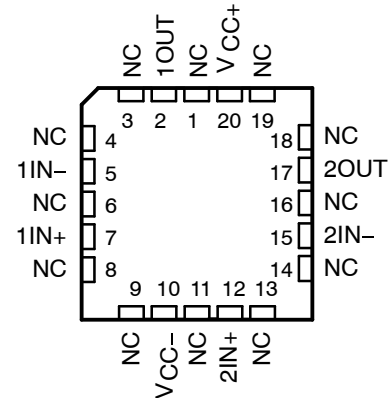

NC – No internal connection

ORDERING INFORMATION

T_A	V_{IOmax} AT 25°C	PACKAGE†		ORDERABLE PART NUMBER	TOP-SIDE MARKING
0°C to 70°C	6 mV	PDIP (P)	Tube	MC1458P	MC1458P
		SOIC (D)	Tube	MC1458D	
			Tape and reel	MC1458DR	MC1458
		SOP (PS)	Tape and reel	MC1458PSR	M1458
-55°C to 125°C	5 mV	CDIP (JG)	Tube	MC1558JG	MC1558JG
		CDIP (JGB)	Tube	MC1558JGB	MC1558JGB
		LCCC (FK)	Tube	MC1558FK	MC1558FK

† Package drawings, standard packing quantities, thermal data, symbolization, and PCB design guidelines are available at www.ti.com/sc/package.

PRODUCTION DATA information is current as of publication date. Products conform to specifications per the terms of Texas Instruments standard warranty. Production processing does not necessarily include testing of all parameters.



POST OFFICE BOX 655303 • DALLAS, TEXAS 75265
POST OFFICE BOX 1443 • HOUSTON, TEXAS 77251-1443

Copyright © 2002, Texas Instruments Incorporated
On products compliant to MIL-PRF-38535, all parameters are tested unless otherwise noted. On all other products, production processing does not necessarily include testing of all parameters.

MC1458, MC1558 DUAL GENERAL-PURPOSE OPERATIONAL AMPLIFIERS

SLOS069C - FEBRUARY 1971 - REVISED AUGUST 2010

symbol (each amplifier)

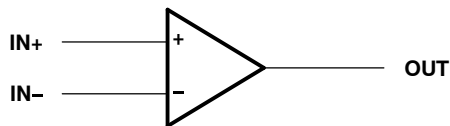

schematic (each amplifier)

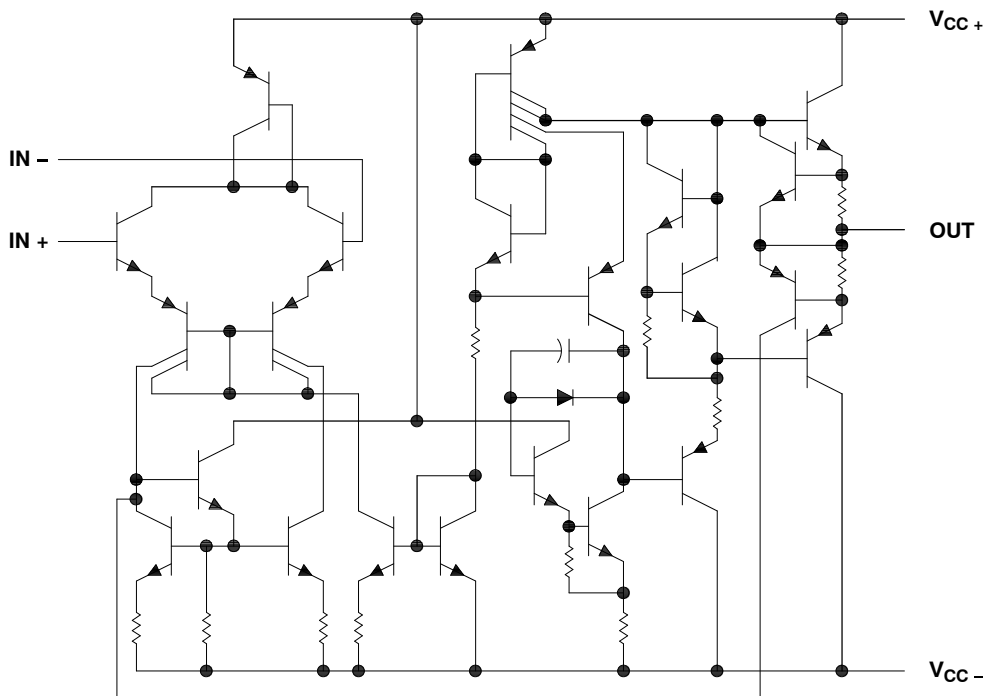

POST OFFICE BOX 655303 • DALLAS, TEXAS 75265
POST OFFICE BOX 1443 • HOUSTON, TEXAS 77251-1443

MC1458, MC1558

DUAL GENERAL-PURPOSE OPERATIONAL AMPLIFIERS

SLOS069C – FEBRUARY 1971 – REVISED AUGUST 2010

absolute maximum ratings over operating free-air temperature range (unless otherwise noted)[†]

Supply voltage, V_{CC+} (see Note 1):	MC1458	18 V
	MC1558	22 V
Supply voltage, V_{CC-} (see Note 1):	MC1458	-18 V
	MC1558	-22 V
Differential input voltage, V_{ID} (see Note 2)	± 30 V
Input voltage, V_I (either input, see Notes 1 and 3)	± 15 V
Duration of output short circuit (see Note 4)	Unlimited
Operating virtual junction temperature, T_J	150°C
Package thermal impedance, θ_{JA} (see Notes 5 and 6):	D package	97°C/W
	P package	85°C/W
	PS package	95°C/W
Package thermal impedance, θ_{JC} (see Notes 7 and 8):	FK package	5.61°C/W
	JG package	14.5°C/W
Case temperature for 60 seconds: FK package	260°C
Lead temperature 1,6 mm (1/16 inch) from case for 10 seconds: JG package	300°C
Lead temperature 1,6 mm (1/16 inch) from case for 60 seconds: D, P, or PS package	260°C
Storage temperature range, T_{stg}	-65°C to 150°C

[†] Stresses beyond those listed under "absolute maximum ratings" may cause permanent damage to the device. These are stress ratings only, and functional operation of the device at these or any other conditions beyond those indicated under "recommended operating conditions" is not implied. Exposure to absolute-maximum-rated conditions for extended periods may affect device reliability.

- NOTES:
1. All voltage values, unless otherwise noted, are with respect to the midpoint between V_{CC+} and V_{CC-} .
 2. Differential voltages are at $IN+$ with respect to $IN-$.
 3. The magnitude of the input voltage must never exceed the magnitude of the supply voltage or 15 V, whichever is less.
 4. The output can be shorted to ground or either power supply. For the MC1558 only, the unlimited duration of the short circuit applies at (or below) 125°C case temperature or 70°C free-air temperature.
 5. Maximum power dissipation is a function of $T_J(\max)$, θ_{JA} , and T_A . The maximum allowable power dissipation at any allowable ambient temperature is $P_D = (T_J(\max) - T_A)/\theta_{JA}$. Operating at the absolute maximum T_J of 150°C can affect reliability.
 6. The package thermal impedance is calculated in accordance with JESD 51-7.
 7. Maximum power dissipation is a function of $T_J(\max)$, θ_{JC} , and T_C . The maximum allowable power dissipation at any allowable case temperature is $P_D = (T_J(\max) - T_C)/\theta_{JC}$. Operating at the absolute maximum T_J of 150°C can affect reliability.
 8. The package thermal impedance is calculated in accordance with MIL-STD-883.

recommended operating conditions

		MIN	MAX	UNIT
$V_{CC\pm}$	Supply voltage	±5	±15	V
T_A	Operating free-air temperature range	MC1458	0 70	°C
		MC1558	-55 125	



MC1458, MC1558 DUAL GENERAL-PURPOSE OPERATIONAL AMPLIFIERS

SLOS069C – FEBRUARY 1971 – REVISED AUGUST 2010

electrical characteristics at specified free-air temperature, $V_{CC\pm} = \pm 15\text{ V}$

PARAMETER	TEST CONDITIONS†	MC1458			MC1558			UNIT
		MIN	TYP	MAX	MIN	TYP	MAX	
V_{IO} Input offset voltage	$V_O = 0$	25°C	1	6	1	5	mV	
		Full range	7.5		6			
I_{IO} Input offset current	$V_O = 0$	25°C	20	200	20	200	nA	
		Full range	300		500			
I_{IB} Input bias current	$V_O = 0$	25°C	80	500	80	500	nA	
		Full range	800		1500			
V_{ICR} Common-mode input voltage range		25°C	±12	±13	±12	±13	V	
		Full range	±12		±12			
V_{OM} Maximum peak output voltage swing	$R_L = 10\text{ k}\Omega$	25°C	±12	±14	±12	±14	V	
	$R_L \geq 10\text{ k}\Omega$	Full range	±12		±11			
	$R_L = 2\text{ k}\Omega$	25°C	±10	±13	±10	±13		
	$R_L \geq 2\text{ k}\Omega$	Full range	±10		±10			
A_{VD} Large-signal differential voltage amplification	$R_L \geq 2\text{ k}\Omega, V_O = \pm 10\text{ V}$	25°C	20	200	50	200	V/mV	
		Full range	15		25			
B_{OM} Maximum-output-swing bandwidth (closed loop)	$R_L = 2\text{ k}\Omega, A_{VD} = 1, THD \geq 5\%$	25°C	14		14		kHz	
B_1 Unity-gain bandwidth		25°C	1		1		MHz	
ϕ_m Phase margin	$A_{VD} = 1$	25°C	65		65		deg	
		Gain margin	11		11			
r_i Input resistance		25°C	0.3	2	0.3*	2	M Ω	
r_o Output resistance	$V_O = 0,$ See Note 9	25°C	75		75		Ω	
C_i Input capacitance		25°C	1.4		1.4		pF	
z_{ic} Common-mode input impedance	$f = 20\text{ Hz}$	25°C	200		200		M Ω	
CMRR Common-mode rejection ratio	$V_{IC} = V_{ICR}\text{ min}, V_O = 0$	25°C	70	90	70	90	dB	
		Full range	70		70			
k_{SVS} Supply-voltage sensitivity ($\Delta V_{IO}/\Delta V_{CC}$)	$V_{CC} = \pm 9\text{ V to } \pm 15\text{ V}, V_O = 0$	25°C	30	150	30	150	$\mu\text{V/V}$	
		Full range	150		150			
V_n Equivalent input noise voltage (closed loop)	$A_{VD} = 100, f = 1\text{ kHz}, R_S = 0, BW = 1\text{ Hz}$	25°C	45		45		nV/ $\sqrt{\text{Hz}}$	
I_{OS} Short-circuit output current		25°C	±25	±40	±25	±40	mA	
I_{CC} Supply current (both amplifiers)	$V_O = 0, \text{ No load}$	25°C	3.4	5.6	3.4	5	mA	
		Full range	6.6		6.6			
P_D Total power dissipation (both amplifiers)	$V_O = 0, \text{ No load}$	25°C	100	170	100	150	mW	
		Full range	200		200			
V_{O1}/V_{O2} Crosstalk attenuation		25°C	120		120		dB	

*On products compliant to MIL-PRF-38535, this parameter is not production tested.

† All characteristics are specified under open-loop operating conditions with zero common-mode input voltage, unless otherwise specified. Full range for MC1458 is 0°C to 70°C and for MC1558 is -55°C to 125°C.

NOTE 9: This typical value applies only at frequencies above a few hundred hertz because of the effect of drift and thermal feedback.



MC1458, MC1558 DUAL GENERAL-PURPOSE OPERATIONAL AMPLIFIERS

SLOS069C – FEBRUARY 1971 – REVISED AUGUST 2010

operating characteristics, $V_{CC\pm} = \pm 15\text{ V}$, $C_L = 100\text{ pF}$, $T_A = 25^\circ\text{C}$ (see Figure 1)

PARAMETER		TEST CONDITIONS		MC1458			MC1558			UNIT
				MIN	TYP	MAX	MIN	TYP	MAX	
t_r	Rise time	$V_I = 20\text{ mV}$,	$R_L = 2\text{ k}\Omega$,	0.3			0.3			μs
	Overshoot factor	$V_I = 20\text{ mV}$,	$R_L = 2\text{ k}\Omega$	5			5			%
SR	Slew rate at unity gain	$V_I = 10\text{ V}$,	$R_L = 2\text{ k}\Omega$	0.5			0.5			$\text{V}/\mu\text{s}$

PARAMETER MEASUREMENT INFORMATION

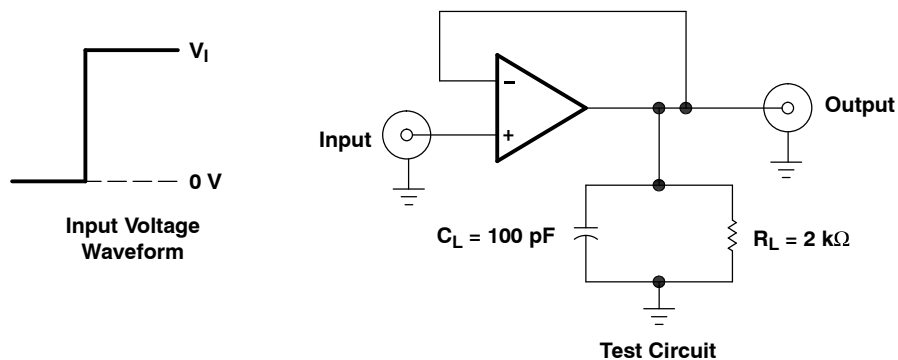

Figure 1. Rise-Time, Overshoot, and Slew-Rate Waveform and Test Circuit

PACKAGING INFORMATION

Orderable Device	Status (1)	Package Type	Package Drawing	Pins	Package Qty	Eco Plan (2)	Lead finish/ Ball material (6)	MSL Peak Temp (3)	Op Temp (°C)	Device Marking (4/5)	Samples
5962-9760301Q2A	ACTIVE	LCCC	FK	20	55	Non-RoHS & Green	SNPB	N / A for Pkg Type	-55 to 125	5962-9760301Q2A MC1558FKB	Samples
5962-9760301QPA	ACTIVE	CDIP	JG	8	50	Non-RoHS & Green	SNPB	N / A for Pkg Type	-55 to 125	9760301QPA MC1558	Samples
MC1458DR	ACTIVE	SOIC	D	8	2500	RoHS & Green	NIPDAU	Level-1-260C-UNLIM	0 to 70	MC1458	Samples
MC1458DRG4	ACTIVE	SOIC	D	8	2500	TBD	Call TI	Call TI	0 to 70		Samples
MC1458P	ACTIVE	PDIP	P	8	50	RoHS & Green	NIPDAU	N / A for Pkg Type	0 to 70	MC1458P	Samples
MC1458PE4	ACTIVE	PDIP	P	8	50	TBD	Call TI	Call TI	0 to 70		Samples
MC1458PSR	LIFEBUY	SO	PS	8	2000	RoHS & Green	NIPDAU	Level-1-260C-UNLIM	0 to 70	M1458	
MC1558FKB	ACTIVE	LCCC	FK	20	55	Non-RoHS & Green	SNPB	N / A for Pkg Type	-55 to 125	5962-9760301Q2A MC1558FKB	Samples
MC1558JG	ACTIVE	CDIP	JG	8	50	Non-RoHS & Green	SNPB	N / A for Pkg Type	-55 to 125	MC1558JG	Samples
MC1558JGB	ACTIVE	CDIP	JG	8	50	Non-RoHS & Green	SNPB	N / A for Pkg Type	-55 to 125	9760301QPA MC1558	Samples

(1) The marketing status values are defined as follows:

ACTIVE: Product device recommended for new designs.

LIFEBUY: TI has announced that the device will be discontinued, and a lifetime-buy period is in effect.

NRND: Not recommended for new designs. Device is in production to support existing customers, but TI does not recommend using this part in a new design.

PREVIEW: Device has been announced but is not in production. Samples may or may not be available.

OBSELETE: TI has discontinued the production of the device.

(2) **RoHS:** TI defines "RoHS" to mean semiconductor products that are compliant with the current EU RoHS requirements for all 10 RoHS substances, including the requirement that RoHS substance do not exceed 0.1% by weight in homogeneous materials. Where designed to be soldered at high temperatures, "RoHS" products are suitable for use in specified lead-free processes. TI may reference these types of products as "Pb-Free".

RoHS Exempt: TI defines "RoHS Exempt" to mean products that contain lead but are compliant with EU RoHS pursuant to a specific EU RoHS exemption.

Green: TI defines "Green" to mean the content of Chlorine (Cl) and Bromine (Br) based flame retardants meet JS709B low halogen requirements of <=1000ppm threshold. Antimony trioxide based flame retardants must also meet the <=1000ppm threshold requirement.